

# Electrical Workshops Week 1

...

**What is electrical + pneumatics?**

**...**

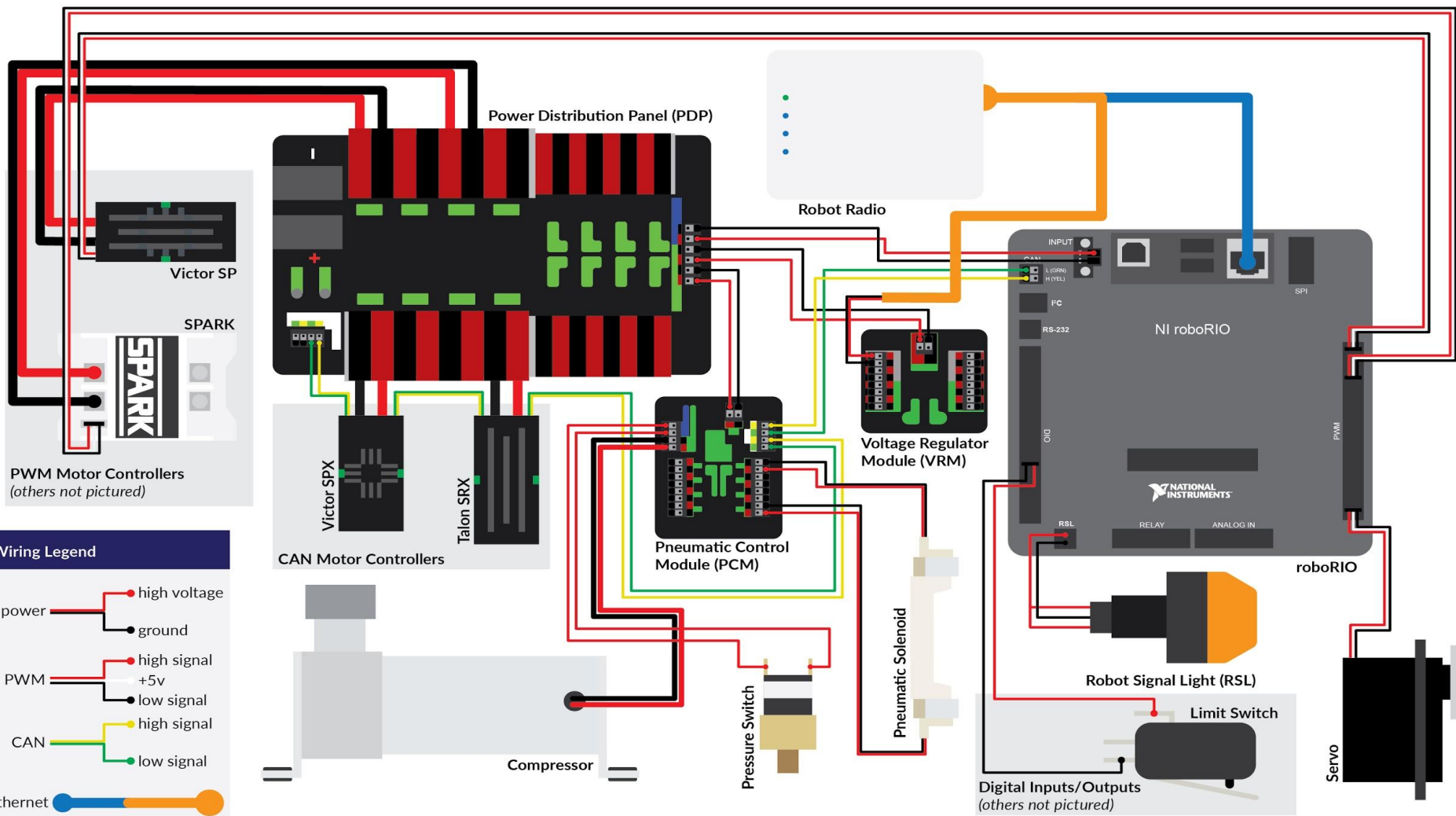

### Wiring Legend

- high voltage power
  - ground
- high signal PWM
  - low signal
- high signal CAN
  - low signal
- ethernet

# Components Part 1

# Battery

12 Volt Nominal

Lead Acid

Safety: Hold with both hands

Red = Positive

Black = Negative



# Circuit Breaker

Opens, closes the circuit



For the first time, don't turn on the circuit breaker before checking ALL connections



# Power Distribution Panel (PDP)

Distributes power throughout the robot

In order to prevent damage to components from overload of power, fuses are added to the PDP



Make sure you add fuses

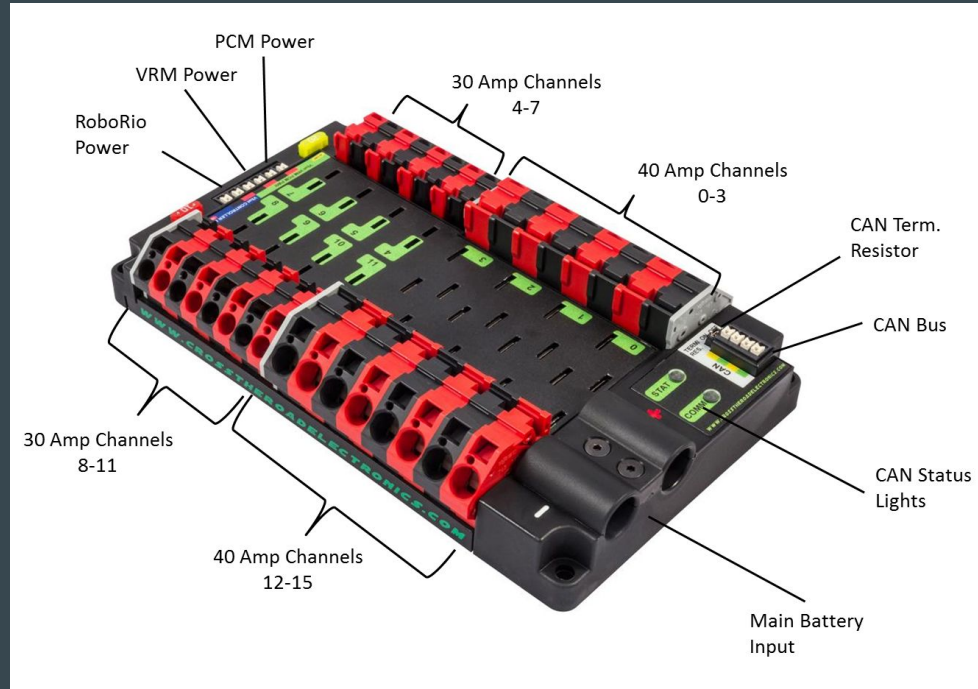

# Power Distribution Panel (PDP) Cont

Resettable Fuses: 40A, 30A, 20A, 10A, 5A

Protects from overcurrent; prevents fires

Fuses (non-resettable): 10A, 20A





# Voltage Regulator Module (VRM)

Regulates voltage from fluctuating input from the battery

5 Volt and 12 Volt output



# RoboRio

Brain of the robots

Runs code that controls ESC  
(Electronic Speed Controllers)



# Speed Controllers (Talon SRX)

Supports CAN (Control Area Network)  
and PWM (Pulse Width Modulation)

Expensive (\$90)



Make sure you don't switch  
the green and yellow wires  
while wiring

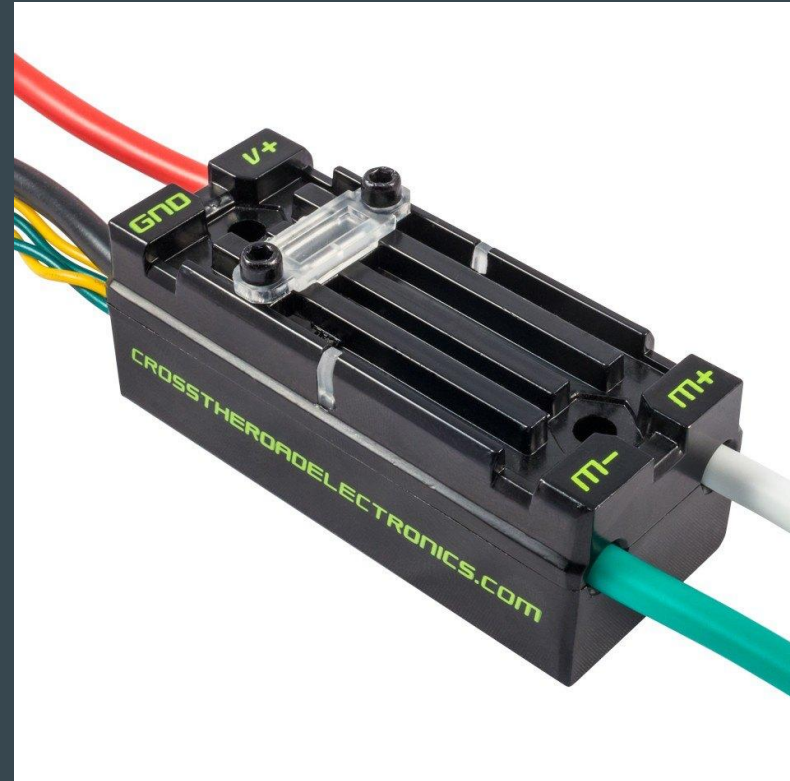

# Speed Controllers (REV Spark)

Supports PWM (Pulse Width Modulation)

Less expensive (\$40)



# Robot Signal Light (RSL)

Signals if the robot is connected or not

## ➡ RSL Indicators

Light Code	Meaning
<b>Solid ON</b>	Autonomous enabled
<b>Solid ON but blinks off every 1.5 sec</b>	Teleop enabled
<b>Slow blink (900ms ON / 900ms OFF)</b>	System disabled by system watchdog, user watchdog, or driver station set to disabled
<b>Fast-slow (200ms ON / 900ms OFF)</b>	Low battery (<12V) or no user code AND system disabled either by system watchdog, user watchdog, or Driver Station set to disabled.
<b>Fast (200ms ON / 200ms OFF)</b>	System error; no Driver station communication; bad cRIO image, bad team ID, extensive communication errors



**Now let's see if we can identify  
these components on the robot!**

...

# Electrical Workshops Week 2



# Components Part 2



# Air Cylinders

Air flows in and out to move the cylinder

Warning: Make sure to use the correct size tubing



# Air Tanks

Air is stored here



# Compressor

Compress air

Has own manifold

120 Psi



# Pressure Switch

Senses pressure from compressor

Prevents compressor from going over 120psi



# Regulator

Regulates pressure to 60psi



# Manifold

Connects tubes

Allows one tube to connect to multiple



# Solenoid

Opens and closes to allow air to go to cylinders

Controlled by Pneumatic Control  
Module



# Pneumatic Control Module (PCM)

Controls the solenoids

Controls the compressor





# Electrical Tools & Crimps

...

# JST

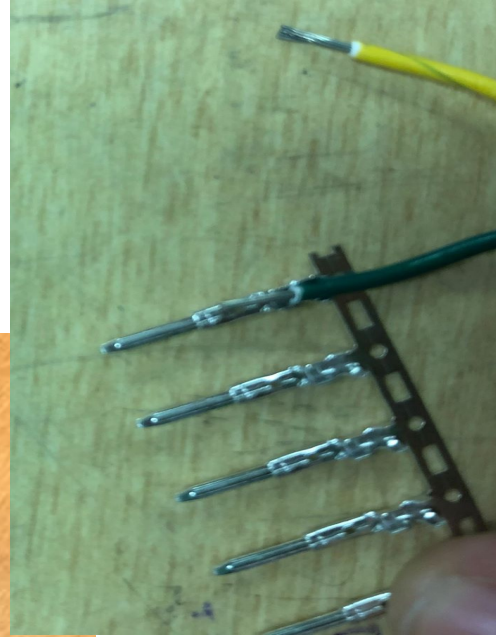

PWM



# Ferrule



# Ferrule

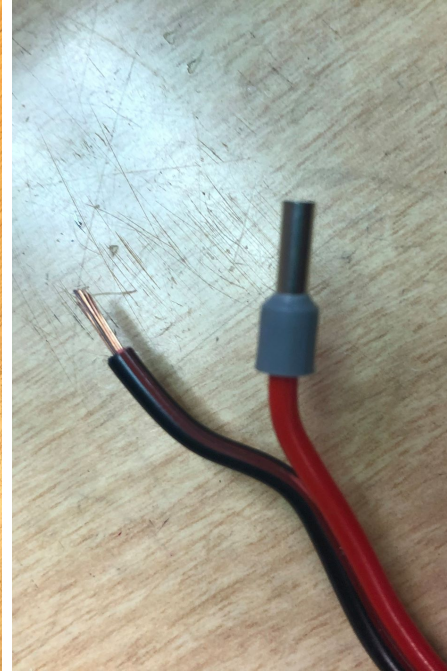

# Andersen

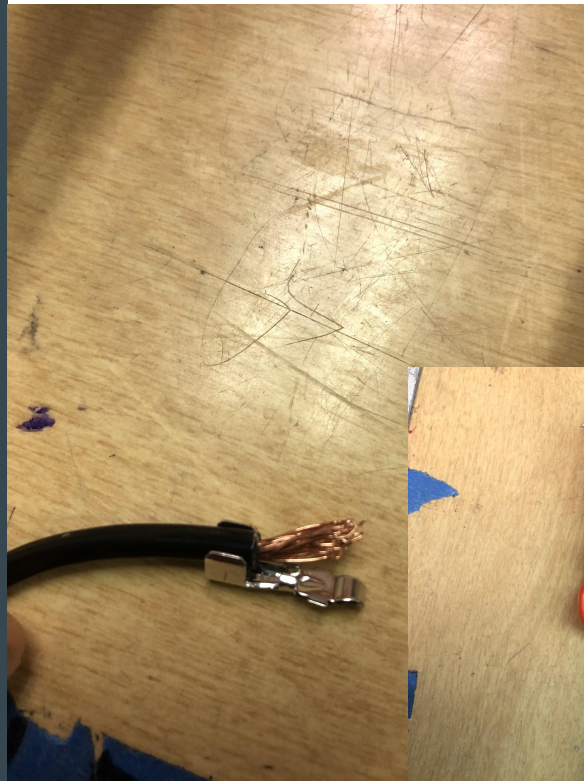

---